



ZHEJIANG A-CRYSTAL

ELECTRONIC TECHNOLOGY CO., LTD.



Issue	June 13, 2023
Rev.	1.0
Page	9

CRYSTAL UNIT SPECIFICATIONS

客户批准 Customer Approval

(请批准后回签一份 Please Return A Copy With Approval)

Customer	
Custome P/N	
Product	TUNING FORK CRYSTAL
Spec	DTLF206/25.600~307.200K
A-Crystal P/N	AD2 Series

Drawn	Checked	Approved
<i>caogaobang</i>	<i>tanglong</i>	<i>huanqweilong</i>



1. ELECTRICAL SPECIFICATIONS

1.1 Hold Type: DTLF206

Parameter	Symb	Electrical Specification				Condition
		Min	Type	Max	Units	
Frequency Range	F_0	25.600	32.768	307.200	KHz	
Frequency Tolerance	$\Delta f/f_0$	± 5	± 20	± 100	PPM	REF TO 25°C
Temperature Coefficient	K	-0.034 ± 0.006			ppm/(°C) ²	
Turnover Temperature	T_{TO}	20	25	30	°C	
Operating Temperature Range	T_{OP}	-10 -40		+60 +85	°C	
Storage Temperature Range	T_{ST}	-40		+85	°C	
Quality Factor	Q	60,000			Typ	
Series Resistance	R_1	25	30	50	KΩ	REF TO 25°C
Shunt Capacitance	C_0	0.9	1.8	2.0	Typ	0.9~2.0PF
Motional Capacitance	C_1		3.0	4.0	Ff TYP	
Load Capacitance	C_L	6	12.5	30	PF	
Insulator Resistance	IR	500			MΩ	DC100V ± 15V
Drive Level	DL			1.0	μW	
Capacitance rati	R		450		TYP	
Aging Rate	Δ/f	± 3		± 5	PPM	at 25°C ± 3°C
Moist are Sensitivity Level	MSL		1			J-STD-033
Package type	Φ2.0*6.0					



1.2 Dimension (Unit: mm)

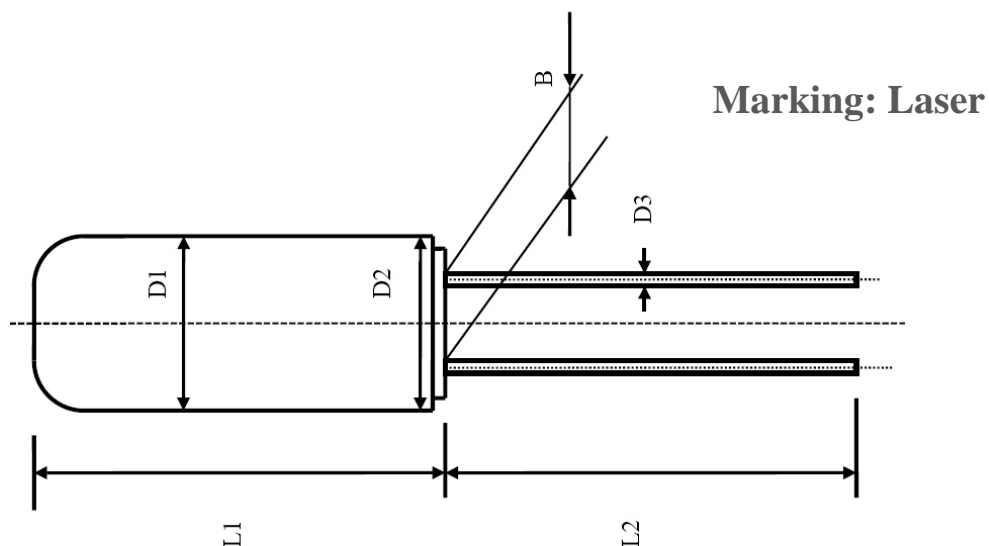

型号/尺寸	L1	L2	D1	D2	D3	B
2*6	6.2Max	5.0 in	1.95±0.1	2.0±0.1	0.2±0.05	0.65±0.05

1.3 The soldering requirements



波峰焊接
Wave Solder Profile

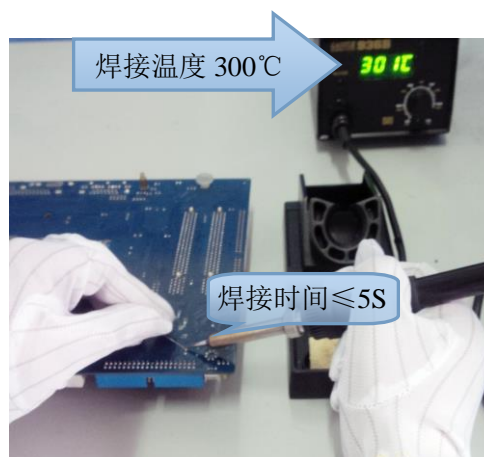

手工焊接
Manual Welding

1.3 Equivalent Circuits

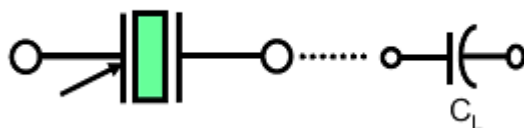

Symbol for crystal unit

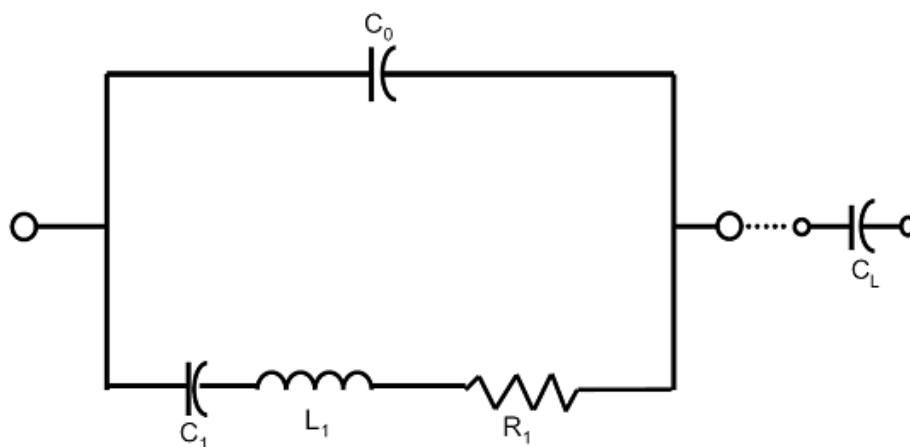



2. PACKING

2.1 Section of package

Package is made of corrugated paper with thickness of 0.8cm. Package has 16 inner boxes, each box has 10 bag

2.1.1 Quantity of package

Per plastic bag 1000 pieces of Crystal Resonators

Per inner box 10 bag

Per package 16 inner boxes

(160000 pieces of Crystal Resonators)

2.1.2 Inner Box Dimensions (Unit: mm)

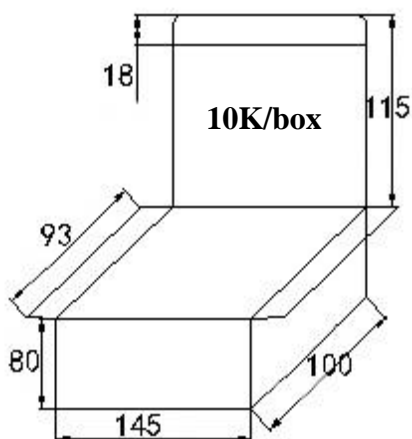

2.1.3 Dimensions and Mark (Unit: mm)

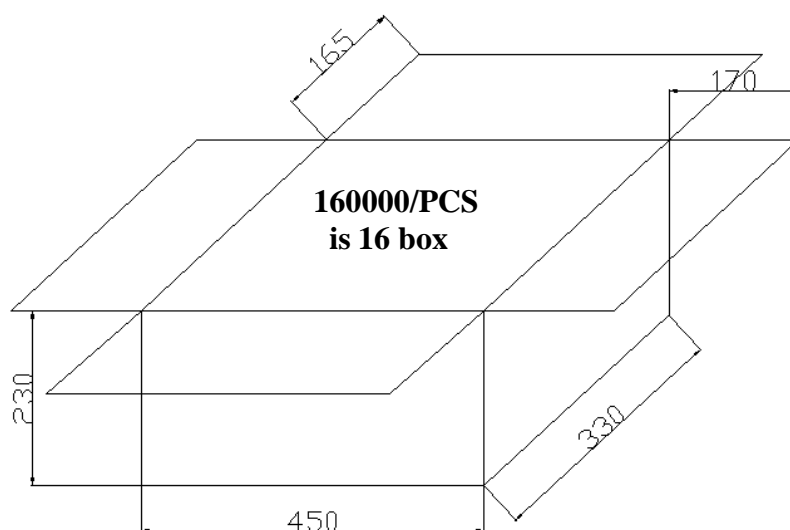



ZHEJIANG A-CRYSTAL

ELECTRONIC TECHNOLOGY CO., LTD.



3. Products Code

3.1 DIP CRYSTAL RESONATORS/KHz

公司代码 浙江一晶	产品型号 (2位)	工作频率 (全频点位数)	负载电容 (1位字母)	调整频差 (2位字母)	温度频差 (1位字母)	工作温度 (1位字母)	其它
A-crystal Logo	Package	Nominal Frequency	Load Capacitance	Frequency Tolerating	Freq Temp Characteristics	Operating Temperture Range	Others
A	D2 (DTLF206)	32.768K	A = 12.5PF	01=5PPM	T = 温度系数	1=0~50	Special
		40.000K	B = 10PF	02=10PPM		2=-10~60	
			C = 9PF	03=20PPM		3=-10~70	
			D = 8PF	04=30PPM		4=-20~70	
			E = 7PF	05=40PPM		5=-30~85	
			F = 6PF	06=50PPM		6=-40~85	
			G = 16PF	07=100PPM			
			H = 18PF				
			J = 20PF				
			K = 22PF				
			L = 30PF				