



**ZHEJIANG A-CRYSTAL**  
ELECTRONIC TECHNOLOGY CO., LTD.



Issue	June 13, 2023
Rev.	1.0
Page	9

## CRYSTAL UNIT SPECIFICATIONS

客户批准 Customer Approval

(请批准后回签一份 Please Return A Copy With Approval)

Customer	
Customer P/N	
Product	TUNING FORK CRYSTAL
Spec	DTLF308/32.768~100.000K
A-Crystal P/N	AD3 Series

Drawn	Checked	Approved
<i>caogaobang</i>	<i>tanglong</i>	<i>huangweilong</i>



## 1. ELECTRICAL SPECIFICATIONS

### 1.1 Hold Type: DTLF308

Parameter	Symb	Electrical Specification				Condition
		Min	Type	Max	Units	
Frequency Range	F <sub>0</sub>	32.768		100.000	KHz	
Frequency Tolerance	$\Delta f/f_0$	$\pm 5$	$\pm 20$	$\pm 100$	PPM	REF TO 25°C
Temperature Coefficient	K	-0.034 $\pm$ 0.006			ppm/(°C) <sup>2</sup>	
Turnover Temperature	T <sub>TO</sub>	20	25	30	°C	
Operating Temperature Range	T <sub>OP</sub>	-10 -40		+60 +85	°C	
Storage Temperature Range	T <sub>ST</sub>	-40		+85	°C	
Quality Factor	Q	60,000			Typ	
Series Resistance	R <sub>1</sub>	25	30	50	K $\Omega$	REF TO 25°C
Shunt Capacitance	C <sub>0</sub>	0.9	1.8	2.0	Typ	0.9~2.0PF
Motional Capacitance	C <sub>1</sub>		2.1	4.0	Ff TYP	
Load Capacitance	C <sub>L</sub>	6	12.5	30	PF	
Insulator Resistance	IR	500			M $\Omega$	DC100V $\pm$ 15V
Drive Level	DL			1.0	$\mu$ W	
Capacitance rati	R		450		TYP	
Aging Rate	$\Delta/f$	$\pm 3$		$\pm 5$	PPM	at 25°C $\pm$ 3°C
Moist are Sensitivity Level	MSL		1			J-STD-033
Package type	$\Phi 3.0*8.0$					



1.2 Dimension (Unit: mm)

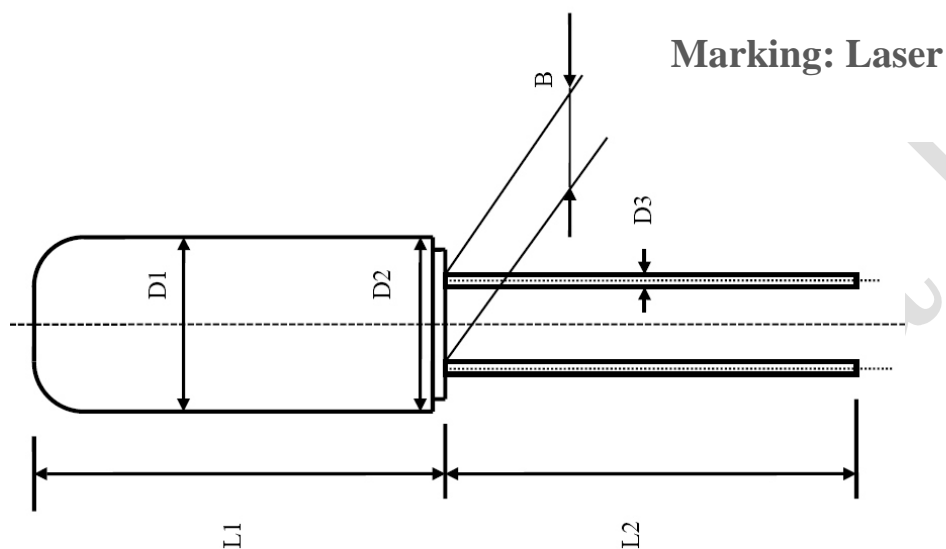

型号/尺寸	L1	L2	D1	D2	D3	B
3*8	8.3Max	9. Min	$2.95 \pm 0.1$	$3.0 \pm 0.1$	$0.3 \pm 0.05$	$0.8 \pm 0.05$

1.3 The soldering requirements

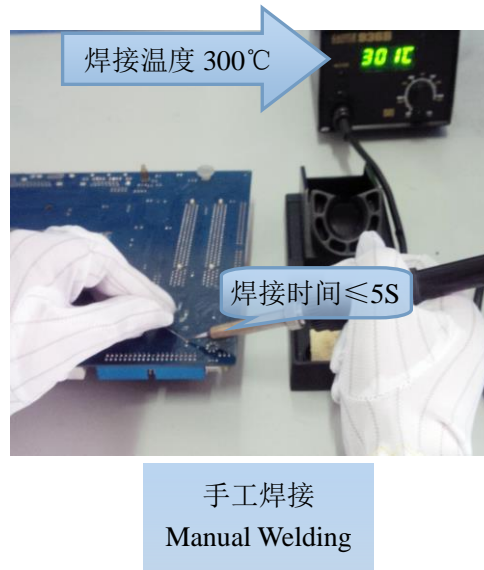
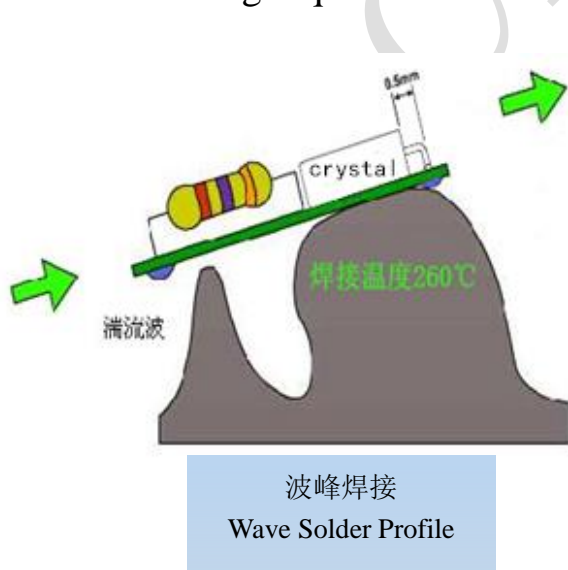

### 1.4 Equivalent Circuits

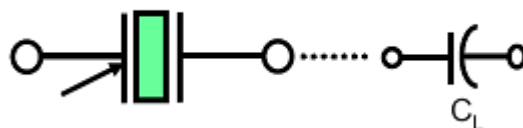

Symbol for crystal unit

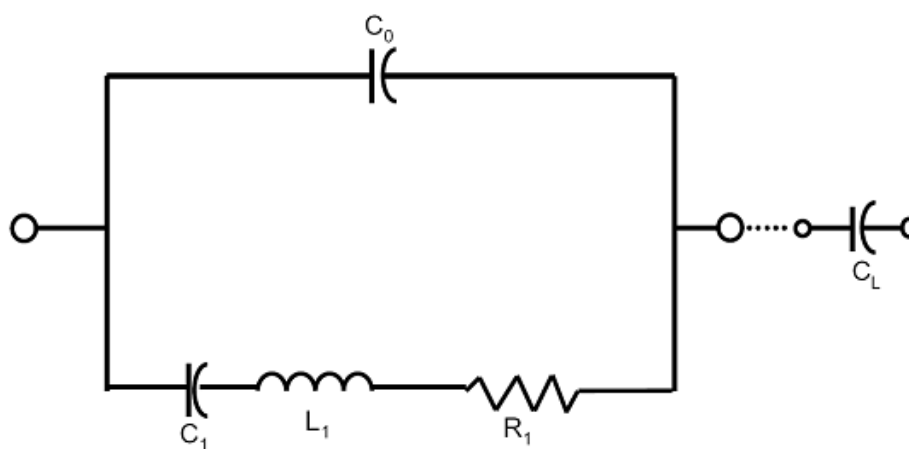



## 2. PACKING

### 2.1 Section of package

Package is made of corrugated paper with thickness of 0.8cm. Package has 10 inner boxes, each box has 10 bag

#### 2.1.1 Quantity of package

Per plastic bag 1000 pieces of Crystal Resonators

Per inner box 10 bag (1k/bag)

Per package 10 inner boxes

(100000 pieces of Crystal Resonators)

#### 2.1.2 Inner Box Dimensions (Unit: mm)

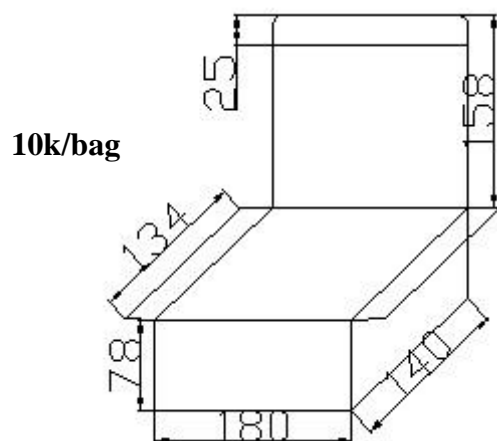

#### 2.1.3 Dimensions and Mark (Unit: mm)

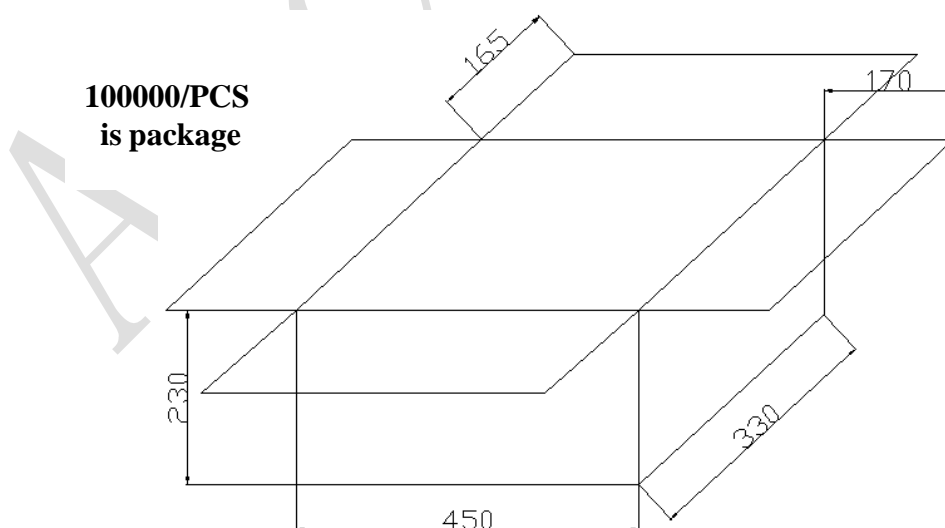



ZHEJIANG A-CRYSTAL

ELECTRONIC TECHNOLOGY CO., LTD.



### 3. Products Code

#### 3.1 DIP CRYSTAL RESONATORS/KHz

公司代码 浙江一晶	产品型号 (2位)	工作频率 (全频点位数)	负载电容 (1位字母)	调整频差 (1位字母)	温度频差 (1位字母)	工作温度 (1位字母)	其它
A-crystal Logo	Package	Nominal Frequency	Load Capacitance	Frequency Tolerating	Freq Temp Characteristics	Operating Temperature Range	Others
A	D3 (DTLF308)	32.768K	A = 12.5PF	01=5PPM	T = 温度系数	1=0~50	Special
		40.000K	B = 10PF	02=10PPM		2=-10~60	
			C = 9PF	03=20PPM		3=-10~70	
			D = 8PF	04=30PPM		4=-20~70	
			E = 7PF	05=40PPM		5=-30~85	
			F = 6PF	06=50PPM		6=-40~85	
			G = 16PF	07=100PPM		7=-40~105	
			H = 18PF			8=-40~125	
			J = 20PF				
			K = 22PF				
			L = 30PF				